

Isolated Digital Input board
for PCI Express

DI-32L-PE



* Specifications, color and design of the products are subject to change without notice.

Features

Opto-coupler isolated input (supporting current sink output)

This product has the opto-coupler isolated input 32ch (supporting current sink output) whose response speed is 200μsec. Common terminal provided per 16ch, capable of supporting a different external power supply Supporting driver voltages of 12 - 24 VDC for input

Opto-coupler bus isolation

As the PCI Express bus (PC) is isolated from the input interfaces by opto-couplers, this product has excellent noise performance.

You can use all of the input signals as interrupt events.

You can use all of the input signals as interrupt events and also disable or enable the interrupt in bit units and select the interrupt edge.

Windows/Linux compatible driver libraries are attached.

Using the attached driver library API-PAC(W32) makes it possible to create applications of Windows/Linux. In addition, a diagnostic program by which the operations of hardware can be checked is provided.

This product has a digital filter to prevent input signals from carrying noise or a chattering.

This product has a digital filter to prevent input signals from carrying noise or a chattering. All input terminals can be added a digital filter, and the setting can be performed by software.

Functions and connectors are compatible with PCI compatible board PI-32L(PCI)H.

The functions same with PCI compatible board PI-32L(PCI)H are provided. In addition, as there is compatibility in terms of connector shape and pin assignments, it is easy to migrate from the existing system.

LabVIEW is supported by a plug-in of dedicated library VI-DAQ.

Using the dedicated library VI-DAQ makes it possible to create each application for LabVIEW.

This product is a PCI Express bus-compliant interface board that extends the digital signal input functions of a PC. This product is a 12 - 24VDC opto-coupler isolated type with input 32ch. You can use all of the input signals as interrupt inputs. In addition, digital filter function to prevent wrong recognition of input signals is provided. Windows/Linux driver is bundled with this product. Possible to be used as a data recording device for LabVIEW, with dedicated libraries.

Specification

Item	Specification
Input	
Input format	Opto-coupler isolated input (Compatible with current sink output) (Negative logic *1)
Number of input signal channels	32ch (32ch available for interrupts) (1 common in 16ch)
Input resistance	4.7kΩ
Input ON current	2.0mA or more
Input OFF current	0.16mA or less
Interrupt	32 interrupt input signals are arranged into a single output of interrupt signal INTA. An interrupt is generated at the rising edge (HIGH-to-LOW transition) or falling edge (LOW-to-HIGH transition).
Response time	Within 200μsec
Common	
Built-in power	None
Allowable distance of signal extension	Approx. 50m (depending on wiring environment)
I/O address	Any 32-byte boundary
Interruption level	1 level use
Max. board count for connection	16 boards including the master board
Isolated Power	1000Vrms
External circuit power supply	12 - 24VDC (±10%)
Power consumption	3.3VDC 350mA
Operating condition	0 - 50°C, 10 - 90%RH (No condensation)
Bus specification	PCI Express Base Specification Rev. 1.0a x1
Dimension (mm)	121.69(L) x 110.18(H)
Connector	37 pin D-SUB connector [F (female) type] DCLC-J37SAF-20L9E [mfd by JAE] or equivalent to it
Weight	130g

*1 Data "0" and "1" correspond to the High and Low levels, respectively.

Board Dimensions

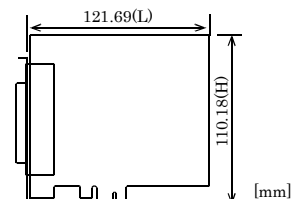

The standard outside dimension (L) is the distance from the end of the board to the outer surface of the slot cover.

Support Software

Windows version of digital I/O driver

API-DIO(WDM)/API-DIO(98/PC)

[Stored on the bundled CD-ROM driver library API-PAC(W32)]

The API-DIO(98/PC) is the Windows version driver library software that provides products in the form of Win32 API functions (DLL). Various sample programs such as Visual Basic and Visual C++, etc and diagnostic program useful for checking operation is provided.

< Operating environment >

OS Windows Vista, Windows XP, Server 2003, 2000

Adaptation language Visual Basic, Visual C++, Visual C#, Delphi, C++ Builder

You can download the updated version from the CONTEC's Web site (<http://www.contec.com/apipac/>). For more details on the supported OS, applicable language and new information, please visit the CONTEC's Web site.

Linux version of digital I/O driver API-DIO(LNX)

[Stored on the bundled CD-ROM driver library API-PAC(W32)]

The API-DIO(LNX) is the Linux version driver software which provides device drivers (modules) by shared library and kernel version. Various sample programs of gcc are provided.

< Operating environment >

OS RedHatLinux, TurboLinux
(For details on supported distributions, refer to Help available after installation.)

Adaptation language gcc

You can download the updated version from the CONTEC's Web site (<http://www.contec.com/apipac/>). For more details on the supported OS, applicable language and new information, please visit the CONTEC's Web site.

Data acquisition VI library for LabVIEW VI-DAQ (Available for downloading (free of charge) from the CONTEC web site.)

This is a VI library to use in National Instruments LabVIEW. VI-DAQ is created with a function form similar to that of LabVIEW's Data Acquisition VI, allowing you to use various devices without complicated settings. See <http://www.contec.com/vidaq/> for details and download of VI-DAQ.

Cable & Connector

Cable (Option)

Flat Cable with Two 37-pin D- SUB Connectors
: PCB37P-1.5 (1.5m)
: PCB37P-3 (3m)
: PCB37P-5 (5m)

Shielded Cable with Two 37-pin D- SUB Connectors
: PCB37PS-0.5P (0.5m)
: PCB37PS-1.5P (1.5m)
: PCB37PS-3P (3m)
: PCB37PS-5P (5m)

Flat Cable with One 37-pin D- SUB Connector
: PCA37P-1.5 (1.5m)
: PCA37P-3 (3m)
: PCA37P-5 (5m)

Shielded Cable with One 37-pin D- SUB Connector
: PCA37PS-0.5P (0.5m)
: PCA37PS-1.5P (1.5m)
: PCA37PS-3P (3m)
: PCA37PS-5P (5m)

Connector (Option)

37-pin D-SUB Male Connector Set (5 Pieces)

: CN5-D37M

Accessories

Accessories (Option)

Screw Terminal (M3 x 37P)	: EPD-37A *1
Screw Terminal (M3.5 x 37P)	: EPD-37 *1
General Purpose Terminal	: DTP-3A *1
Screw Terminal	: DTP-4A *1
Signal Monitor for Digital I/O	: CM-32(PC)E *1

*1 A PCB37P or PCB37PS optional cable is required separately.

* Check the CONTEC's Web site for more information on these options.

Packing List

Board [DI-32L-PE] ...1
First step guide ... 1
CD-ROM *1 [API-PAC(W32)] ...1

*1 The CD-ROM contains the driver software and User's Guide.

Block Diagram

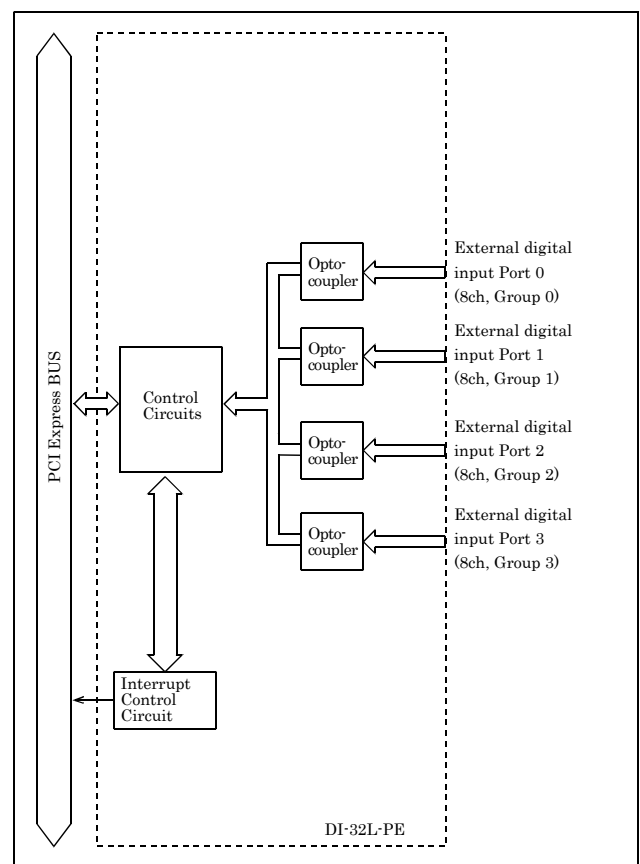

How to connect the connectors

Connector shape

The on-board interface connector (CN1) is used when connecting this product and the external devices.

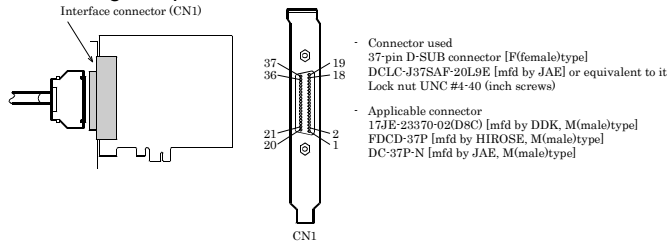

- Connector used
37-pin D-SUB connector [F(female)type]
DCLC-J37SAF-20L9E [mfd by JAE] or equivalent to it
Lock nut UNC #4-40 (finch screws)
- Applicable connector
17JE-23370-02(D8C) [mfd by DDK, M(male)type]
FDCD-37P [mfd by HIROSE, M(male)type]
DC-37P-N [mfd by JAE, M(male)type]

* Please refer to page 2 for more information on the supported cable and accessories.

Connector Pin Assignment

Pin Assignments of Interface Connector (CN1)

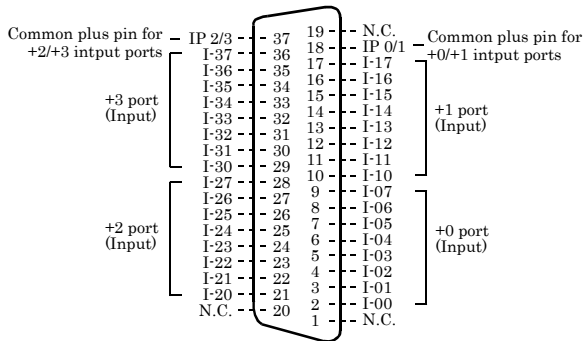

I-00 - I-37	32 input signal pins. Connect output signals from the external device to these pins.
IP 0/1 - IP 2/3	Connect the positive side of the external power supply. These pins are common to 16 input signal pins.
N.C.	This pin is left unconnected.

Connecting Input Signals

Connect the input signals to a device which can be current-driven, such as a switch or transistor output device. The connection requires an external power supply to feed currents.

The board inputs the ON/OFF state of the current-driven device as a digital value.

Input Circuit

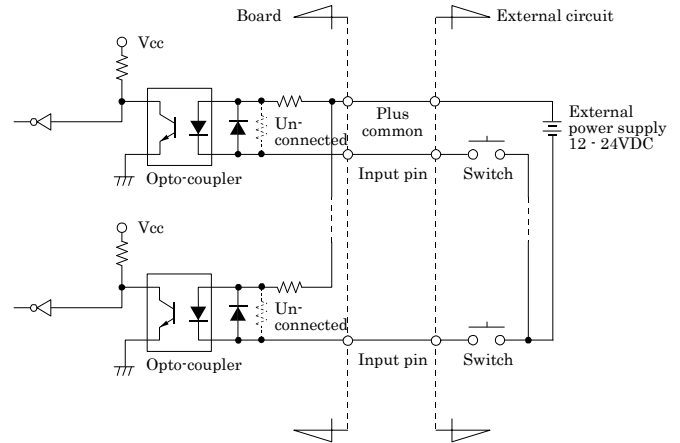

* I-xx represents the input pin.

The input circuits of interface blocks of this product is illustrated in the image above.

The signal inputs are isolated by opto-couplers (ready to accept current sinking output signals). The board therefore requires an external power supply to drive the inputs. The power requirement for each input pin is about 5.1mA at 24VDC (about 2.6mA at 12VDC).

Connecting a Switch

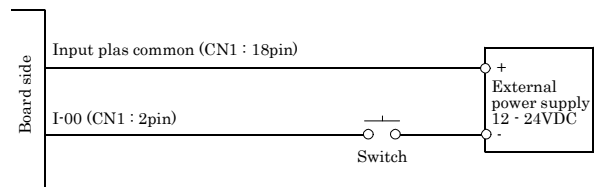

When the switch is ON, the corresponding bit contains 1.

When the switch is OFF, by contrast, the bit contains 0.

Connecting the Sink Type Output and Sink Output Support Input

The following example shows a connection between a sink type output (output board) and a sink output support input (input board). Refer to this connection example when you connect such boards to each other.

