

Isolated Digital Output Module for USB2.0

DO-32(USB)



* Specifications, color and design of the products are subject to change without notice.

This product is a USB 2.0 compliant module that extends the digital signal output functions of a PC.

This product is a high-voltage (12 - 48VDC) opto-coupler isolated type with open-collector output 32ch.

Using the expansion module available as an option can increase the number of output channels. In addition, this product has an attachment that allows this product to be directly attached onto 35-mm DIN rails useful for embedded applications. Windows driver is bundled with this product. Possible to be used as a data recording device for LabVIEW, with dedicated libraries.

Features

Opto-coupler isolated open-collector output (current sink type)

Equipped with opto-coupler isolated open-collector output 16ch (current sink type). Common terminal provided per 16ch, capable of supporting a different external power supply Supporting driver voltages of 12 - 24VDC for input and 12 - 48VDC for output

Conforming to the USB1.1 and USB2.0 Standards and supporting the internal and external power supplies

Compatible to USB1.1/USB2.0 and capable to achieve high speed transfer at HighSpeed (480 Mbps).

Not necessary to power this product externally as the bus power of USB is used. Capable of accepting an external power supply (optional AC adapter) when lower power consumption is required, e.g., for use with a notebook PC

Opto-coupler bus isolation

As the USB (PC) is isolated from the output interfaces by opto-couplers, this product has excellent noise performance.

Trigger monitor function integrated

The CPU inside the module can report status changes (rise and fall) to the host in a minimum cycle of 1ms.

Easy to increase the number of output channels using an expansion module

Adding optional modules (up to 3 units) can easily increase the number of output channels.

The unique structure for connection by stacking enables easy and compact system configuration.

Screw-less connector plug facilitating wiring and plugging/unplugging

Wiring and plugging/unplugging are easy as the screw-less connector plug is used.

Capable of being mounted on 35-mm DIN rails

The module is equipped with an attachment for mounting on 35-mm DIN rails on the back, allowing the module to be attached onto and detached from DIN rails.

Output circuit with a built-in zener diode for protection from surge voltage

The output circuit is connected with a zener diode for protection from surge voltage.

The output rating is 150mA at a maximum of 24VDC or 50mA at a maximum of 48VDC per ch.

LabVIEW is supported by a plug-in of dedicated library VI-DAQ.

Using the dedicated library VI-DAQ makes it possible to create each application for LabVIEW.

Packing List

USB module [DO-32(USB)] ...1
 First step guide ... 1
 CD-ROM *1 [API-USBP(WDM)]...1
 Interface connector (plugs) FMC1,5/18-ST-3.5...2
 Power connector MC1,5/3-ST-3,5 ...1
 USB cable (1.8m)...1
 Rubber feet...4
 Magnet...2

*1 The CD-ROM contains the driver software and User's Guide.

Product Specification

Hardware Specification

Item	Specification	
Output section		
Output format	Opto-isolated open collector output (current sink type) (negative *1)	
Output rating	Output voltage	12 - 48VDC (±15%)
	Output current	Max. 150mA(12 - 24V) (per point), 50mA(36 - 48V) (per point)
Number of output signal points	32 points (16 points/common)	
Response time	1msec(Min.)	
External power	12 - 48VDC (±15%)	
Allowable distance of signal extension	Approx. 50m (depending on wiring environment)	
Communication		
USB transmission speed	12Mbps (full speed), 480Mbps (high speed) *3	
Current consumption	+5VDC 450mA(Max.)	
Others		
Number of modules used at the same time	127 modules (Max.) *4	
Use condition	0 - 50°C 10 - 90%RH (no condensation)	
Physical dimensions (mm)	50.4(W) x 64.7(D) x 94.0(H) (exclusive of protrusions)	
Weight of the module itself	100g	
Module installation method	One-touch connection to 35mm DIN rails (standard connection mechanism provided in the system)	
Expansion module	DI-32(FIT)GY: 3 modules (Max.) consumption current per module: +5VDC 150mA (Max.)	
Compatible plug	FMC1.5/18-ST-3.5 (made by Phoenix Contact corp.) 3.5mm-pitch nominal current: 6A (Max.)	
Compatible wires	AWG24 - 16	

*1 Data"0" corresponds to high-level and data"1" corresponds to low-level.

*2 Data"1" corresponds to high-level and data"0" corresponds to low-level.

*3 USB module executes API function by USB communication. The executing time of API function by USB communication is about several msec in practice (Depending on the contents handled by API function, it may be longer than that). The responding speed of USB module is based on the environment of the host PC being used.

*4 The USB interface can accommodate up to 127 devices on the bus. As a USB hub itself is counted as one device, however, 127 USB modules cannot be connected.

Software Specification

Item	Specification
Support OS	Microsoft Windows Me Microsoft Windows 98 or Second Edition Microsoft Windows XP Professional, Home Edition Microsoft Windows 2000 Professional Microsoft Windows Vista
Support language	Microsoft Visual C++ Ver 5.0, Ver 6.0 Microsoft Visual C++ .NET 2002, 2003 Microsoft Visual Basic Ver 5.0, Ver 6.0 Microsoft Visual Basic .NET 2002, 2003 Microsoft Visual C# .NET 2002, 2003 Borland Delphi Ver 5.0, 6.0 Borland C++ Builder Ver 5.0
System requirement	- PC (IBM PC/AT compatibility, DOS/V) with USB port - CD-ROM drive - Recommend the environment on which the using language can run smoothly

Support Software

Driver Library API-USBP(WDM) (Bundled)

It is the library software, and which supplies command of hardware produced by our company in the form of standard Win32 API function(DLL). Using programming languages supporting Win32API functions, such as Visual Basic and Visual C++ etc., you can develop high-speed application software with feature of hardware produced by our company. In addition, you can verify the operation of hardware using Diagnostic programs.

CONTEC provides download services (at <http://www.contec.com/apiusbp/>) to supply the updated drivers and differential files.

Further details may be found in the help within supplied CD-ROM or the homepage of our company.

< Operating environment >

OS Windows Vista, XP, Server 2003, 2000, Me, 98

Adaptation language Visual Basic, Visual C++, Visual C#, Delphi, C++ Builder

Accessories

Accessories (Option)

Isolated digital output module : DO-32(FIT)GY
(Expansion module)

AC adapter
(input: 90 - 264VAC, output : 5VDC 2.0A) : POA200-20

AC-DC power supply unit
(input: 85 - 132VAC, output: 5VDC 3.0A) : POW-AC13GY

AC-DC power supply unit
(input: 85 - 264VAC, output: 5VDC 2.0A) : POW-AD22GY

DC-DC power supply unit
(input: 10 - 30VDC, output: 5VDC 3.0A) : POW-DD10GY

DC-DC power supply unit
(input: 30 - 50VDC, output: 5VDC 3.0A) : POW-DD43GY

* Further details of the accessories may be verified in the Web site of our company.

Block Diagram

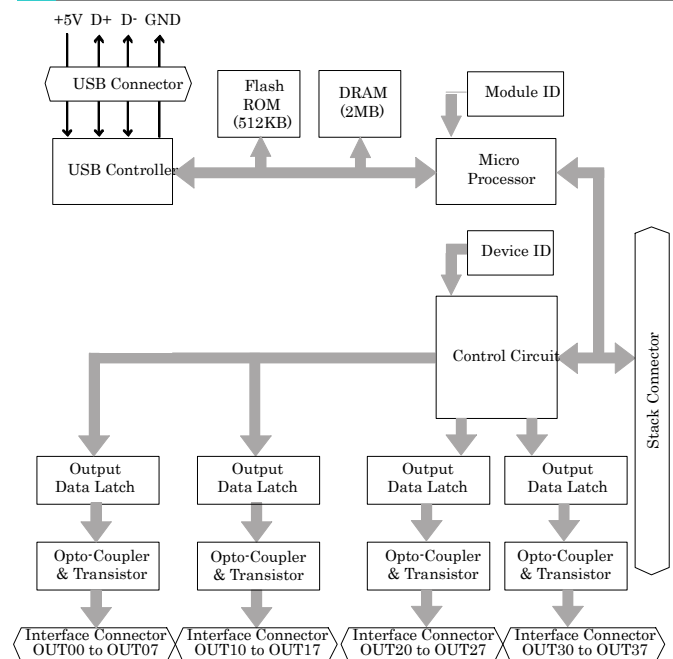

Points

The Device ID is fixed at "0".

Physical Dimensions

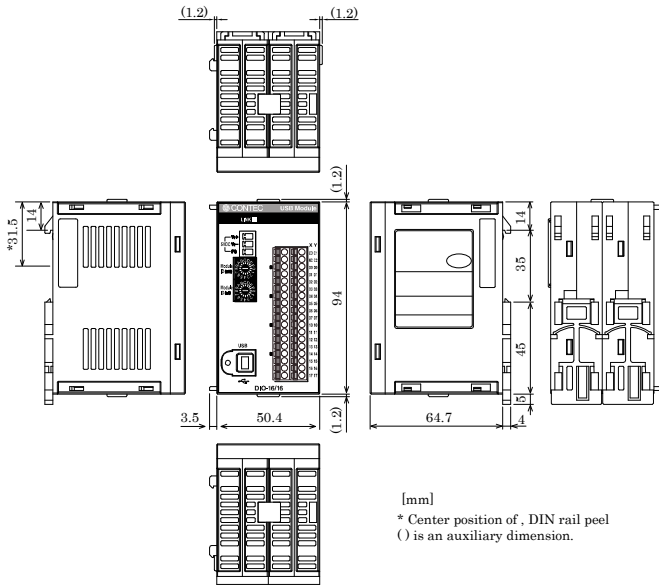

Signal Layout

For connection of this module to an external device, use a pair of 18-pin connectors on the module.

Pin No.	Signal name	Meaning	Pin No.	Signal name	Meaning
C0	COM(+)	Plus common for Output+0, +1 group	C2	COM(+)	Plus common for Output+2, +3group
C1	COM(-)	Minus common for Output+0,+1 group	C3	COM(-)	Minus common for Output+2, +3 group
0	OUT00	Output+0group	20	OUT20	Output+2 group
1	OUT01		21	OUT21	
2	OUT02		22	OUT22	
3	OUT03		23	OUT23	
4	OUT04		24	OUT24	
5	OUT05		25	OUT25	
6	OUT06		26	OUT26	
7	OUT07	Output+1group	27	OUT27	Output+3 group
10	OUT10		30	OUT30	
11	OUT11		31	OUT31	
12	OUT12		32	OUT32	
13	OUT13		33	OUT33	
14	OUT14		34	OUT34	
15	OUT15		35	OUT35	
16	OUT16	36	OUT36		
17	OUT17	37	OUT37		

Connection Method

When connecting the Module to an external device, you can use the supplied connector plug. When wiring the Module, strip off approximately 9 - 10 mm of the covering for the cable, and insert the bare wire by pressing the orange button on the connector plug. Releasing the orange button after the wire is inserted fixes the cable. Compatible wires are AWG 24 - 16.

CAUTION

Removing the connector plug by grasping the cable can break the wire.

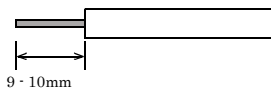
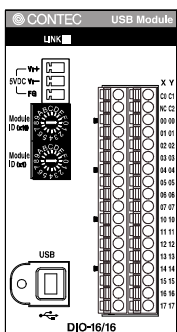

- Compatible plug:
FMC1,5/18-ST-3,5 (made by Phoenix Contact Corp.)
Compatible cable: AWG24 - 16

External Output Circuit

Output Section

Figure shows the output circuit for the interface section. The signal output section consists of an opto-isolated open collector method (current sink type). An external power supply is therefore required for driving the output block of this module. The maximum rated output current is 150 mA (at 12-24 VDC) or 50 mA (at 36-48 VDC) per channel. Although the output transistor of this module is provided with a surge voltage protection circuit (zener diode), it is advisable to apply surge voltage protection to the load side when this module drives an inductive load such as a relay or lamp.

DANGER

When the power is turned on, all output will be OFF.

Output Circuit

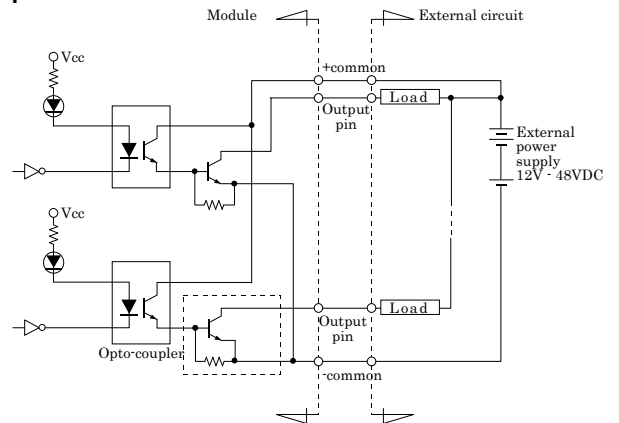

Point

When the power is turned on, all output will be OFF.

Connecting an External Power Supply

The module can be used via only USB cable if it uses bus power. In this situation, the external power supply is not required.

If you want to control the power consumption of the computer with battery, such as Note PC, you can use self-power to provide power for the module. In addition, if you use expansion modules, the self-power is required.

When you use self-power, please use +5VDC input terminal.

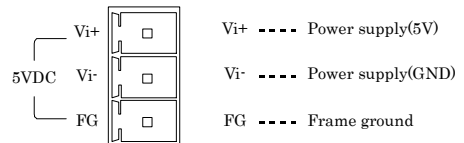

Input plug is 5VDC ±5% input, Laterally operable screw-in type connector is supplied as a standard item. (MC1,5/3-ST-3,5 Phoenix Contact compatible cable:AWG28 - 16)

To supply power using the bundled connector plug (MC1,5/3-ST-3,5), strip the end of the corresponding cable, insert it into the connector plug, then securely screw the plug.

Use an external power supply (available as an option) depending on the operating environment and application.

Category	Model	Input	Output	Physical dimensions(mm)	DIN rail
AC adapter	POA200-20	90 - 264VAC	5.0VDC±5% 2.0A(Max.)	40.0(W) x 105.0(D) x 30.0(H) (exclusive of protrusions)	No
AC-DC power	POW-AD13GY	85 - 132VAC	5.0VDC±5% 3.0A(Max.)	52.4(W)x64.7(D)x94.0(H) (exclusive of protrusions)	Yes
AC-DC power	POW-AD22GY	85 - 265VAC	5.0VDC±5% 2.0A(Max.)	52.4(W)x64.7(D)x94.0(H) (exclusive of protrusions)	Yes
DC-DC power	POW-DD10GY	10 - 30VDC	5.0VDC±5% 3.0A(Max.)	25.2(W)x64.7(D)x94.0(H) (exclusive of protrusions)	Yes
DC-DC power	POW-DD43GY	30 - 50VDC	5.0VDC±5% 3.0A(Max.)	25.2(W)x64.7(D)x94.0(H) (exclusive of protrusions)	Yes

* The consumed current of DO-32(USB) is +5VDC 450mA(Max.) individually.
The consumed current of DO-32(FIT)GY is +5VDC 150mA(Max.) individually.

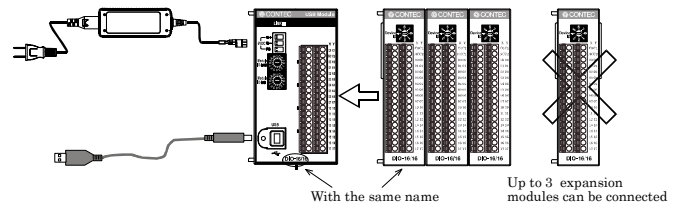
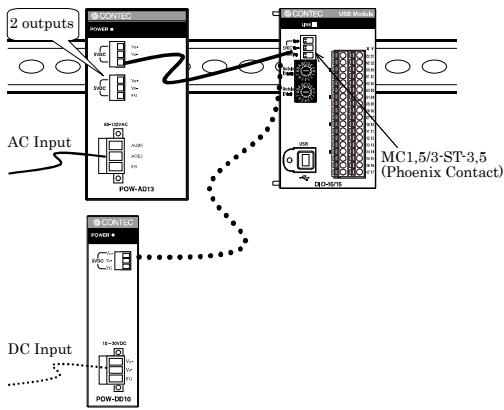

Points

- Up to 3 modules can be connected.
- Adding an expansion module requires an external power supply such as the AC adapter (option).
- Modules functionally incompatible with the USB module cannot be connected. Use dedicated modules.

When using the power supply installable on DIN rail, please use the connector MC1,5/3-ST-3,5 (Phoenix Contact).

Connecting method

To connect the external power supply and USB cable to the unit, take the steps below:

- (1) Connect the external power connector to supply power for the USB module.
- (2) Connect the USB module with computer using USB cable.

To remove the external power supply and USB cable from the unit, take the steps below:

- (1) Remove USB cable.
- (2) Remove external power connector, stop power supplying to the USB module.

⚠ CAUTION

To use the AC adapter, connect it to the USB module first, then plug the AC adapter's connector into a wall outlet.

When the USB module is not used, leave the AC adapter unplugged

Continuously using the AC adapter heated affects its life.

Use the AC adapter not in a closed place but in a well-ventilated place not to be heated. The AC adapter heats up itself when loaded heavily. If the AC adapter is exposed to high temperature or used continuously, you should keep the load at about 80% of the maximum load (at 1.6 A for the POA200-20).

Connecting with Expansion Accessories

When lacking of digital I/O point used to connecting external device, you have to purchase a new same module, and thus it not only increases cost but also doubles installation space. As this module is designed considering the growth in the number of I/O channels, the connectors on the side face can accept additional modules to save the cost and installation space for expansion.

Expansion modules (options) are available to each type of USB module.

Model	Input point	Output channel	Current consumption	Function
DIO-16/16(FIT)GY	16	16	+5VDC 150mA(Max.)	Expansion module for DIO-16/16(USB)
DI-32(FIT)GY	32	None	+5VDC 150mA(Max.)	Expansion module for DI-32(USB)
DO-32 (FIT)GY	None	32	+5VDC 150mA(Max.)	Expansion module for DO-32(USB)

Up to three expansion modules can be connected. For example, the combination of the USB module "DIO-16/16(USB)" and three expansion modules "DIO-16/16(FIT)GY" can be used to control up to 64 inputs and 64 outputs through a single USB port.