

Digital I/O Board with Opto-Isolation for PCI

PIO-16/16L(PCI)H



This board is a PCI-compliant interface board for input/output of digital signals.

The board can input and output digital signals at 12 - 24 VDC.

<PIO-16/16L(PCI)H> can input and output up to 16 channels.

<PI-32L(PCI)H> can input up to 32 channels.

<PO-32L(PCI)H> can output up to 32 channels.

Using the bundled API function library package [API-PAC(W32)], you can create Windows application software for this board in your favorite programming language supporting Win32 API functions, such as Visual Basic or Visual C/C++.

Digital Input Board with Opto-Isolation for PCI

PI-32L(PCI)H

Digital Output Board with Opto-Isolation for PCI

PO-32L(PCI)H

with Driver Library [API-PAC(W32)]

Features

- A different external power supply can be used for each common pin as it is shared by 16 channels.
- The PCI bus (personal computer) and the I/O interface are isolated from each other by an opto-coupler, offering good noise immunity.
- You can use all of the input signals as interrupt inputs. You can also select the interrupt trigger edge of the input signal.
<PIO-16/16L(PCI)H>, <PI-32L(PCI)H>
- The board has a digital filter feature to prevent noise or chatter from causing erroneous inputs.
<PIO-16/16L(PCI)H>, <PI-32L(PCI)H>
- Up to 35VDC, 100mA per signal, max. output.
<PIO-16/16L(PCI)H>, <PO-32L(PCI)H>
- Zener diode connected to output transistors for protection from surge voltage. Overcurrent protective device provided for every eight channels of output transistors.
<PIO-16/16L(PCI)H>, <PO-32L(PCI)H>

Specification

PIO-16/16L(PCI)H

Item	Specification
Input	
Input format	Opto-isolated input (Compatible with current sink output) (Negative logic *1)
Number of input signal channels	16 channels (all available for interrupts) (1 common)
Input resistance	4.7kΩ
Input ON current	2.0mA or more
Input OFF current	0.16mA or less
Interrupt	16 interrupt input signals are arranged into a single output of interrupt signal INTA. An interrupt is generated at the rising edge (HIGH-to-LOW transition) or falling edge (LOW-to-HIGH transition).
Response time	200μsec within
Output	
Output format	Opto-isolated open collector output (current sink type) (Negative logic*1)
Number of output signal channels	16 channels (1 common)
Output rating	Output voltage: 35VDC (Max.) Output current: 100mA (par channel) (Max.)
Residual voltage with output on	0.5V or less (Output current≤50mA), 1.0V or less (Output current≤100mA)
Surge protector	Zener diode RD47FM(NEC) or equivalent
Response time	200μsec within
Common	
I/O address	Any 32-byte boundary
Interruption level	1 level use
Max. board count for connection	16 boards including the master board
Dielectric strength	1000Vrms
External circuit power supply	12 - 24VDC(±10%)
Power consumption	5VDC 200mA (Max.)
Operating condition	0 - 50°C, 10 - 90%RH (No condensation)
Allowable distance of signal extension	Approx. 50m (depending on wiring environment)
PCI bus specification	33bit, 33MHz, Universal key shapes supported *2
Dimension (mm)	121.69(L) x 105.68(H)
Weight	130g

*1 Data "0" and "1" correspond to the High and Low levels, respectively.

*2 This board requires power supply at +5 V from an expansion slot (it does not work on a machine with a +3.3V power supply alone).

Board Dimensions

[PIO-16/L(PCI)H, PI-32L(PCI)H, PO-32L(PCI)H]

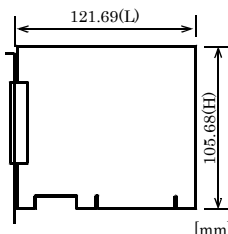

The standard outside dimension (L) is the distance from the end of the board to the outer surface of the slot cover.

PI-32L(PCI)H

Item	Specification
Input section	
Input format	Opto-isolated input (Compatible with current sink output) (Negative logic *1)
Number of input signal channels	32 channels (all available for interrupts) (One common power supply per 16 channels)
Input resistance	4.7kΩ
Input ON current	2.0mA or more
Input OFF current	0.16mA or less
interrupt	32 interrupt input signals are arranged into a single output of interrupt signal INTA. An interrupt is generated at the rising edge (HIGH-to-LOW transition) or falling edge (LOW-to-HIGH transition).
Response time	200μsec within
Common section	
I/O address	Any 32-byte boundary
Interruption level	1 level use
Max. board count for connection	16 boards including the master board
Dielectric strength	1000Vrms
External circuit power supply	12 - 24VDC(±10%)
Power consumption	5VDC 200mA (Max.)
Operating condition	0 - 50°C, 10 - 90%RH (No condensation)
Allowable distance of signal extension	Approx. 50m (depending on wiring environment)
PCI bus specification	33bit, 33MHz, Universal key shapes supported *2
Dimension (mm)	121.69(L) x 105.68(H)
Weight	130g

*1 Data "0" and "1" correspond to the High and Low levels, respectively.

*2 This board requires power supply at +5 V from an expansion slot (it does not work on a machine with a +3.3V power supply alone).

PO-32L(PCI)H

Item	Specification
Output section	
Output format	Opto-isolated open collector output(current sink type) (Negative logic *1)
Number of output signal channels	32 channels(One common power supply per 16 channels)
Output rating	Output voltage: 35VDC (Max.) Output current: 100mA (par channel) (Max.)
Residual voltage with output on	0.5V or less (Output current≤50mA), 1.0V or less (Output current≤100mA)
Surge protector	Zener diode RD47FM(NEC) or equivalent
Response time	200μsec within
Common section	
I/O address	Any 32-byte boundary
Interruption level	Not used
Max. board count for connection	16 boards including the master board
Dielectric strength	1000Vrms
External circuit power supply	12 - 24VDC(±10%)
Power consumption	5VDC 200mA (Max.)
Operating condition	0 - 50°C, 10 - 90%RH (No condensation)
Allowable distance of signal extension	Approx. 50m (depending on wiring environment)
PCI bus specification	33bit, 33MHz, Universal key shapes supported *2
Dimension (mm)	121.69(L) x 105.68(H)
Weight	130g

*1 Data "0" and "1" correspond to the High and Low levels, respectively.

*2 This board requires power supply at +5 V from an expansion slot (it does not work on a machine with a +3.3V power supply alone).

Support Software

You should use CONTEC support software according to your purpose and development environment.

■ Driver Software Package API-PAC(W32) (Bundled)

API-PAC(W32) is the library software that provides the commands for CONTEC hardware products in the form of Windows standard Win32 API functions (DLL). It makes it easy to create high-speed application software taking advantage of the CONTEC hardware using various programming languages that support Win32 API functions, such as Visual Basic and Visual C/C++.

It can also be used by the installed diagnosis program to check hardware operations.

CONTEC provides download services to supply the updated drivers and differential files.

For details, read Help on the bundled CD-ROM or visit the CONTEC's Web site.

< Operating environment >

OS	Windows XP, 2000, NT, Me, 98, etc..
Adaptation language	Visual C/C++, Visual Basic, Delphi, Builder, etc..
Others	Each piece of library software requires 50 megabytes of free hard disk space.

■ Linux version of digital I/O driver API-DIO(LNX)

(Supplied: Stored on the API-PAC(W32) CD-ROM)

This driver is used to control CONTEC digital I/O boards (cards) from within Linux.

You can control CONTEC I/O boards easily using the shared library used by gcc and Kylix, the device driver (module) for each kernel version, and the board (card) configuration program (config).

CONTEC provides download services to supply the updated drivers and differential files.

For details, read Help on the bundled CD-ROM or visit the CONTEC's Web site.

< Operating environment >

OS	RedHatLinux, TurboLinux, etc.. (For details on supported distributions, refer to Help available after installation.)
Adaptation language	gcc, Kylix, etc..
Others	Requires 3 megabytes of free hard disk space.

■ Data acquisition VI library for LabVIEW VI-DAQ

(Free download)

This is a VI library to use in National Instruments LabVIEW.

VI-DAQ is created with a function form similar to that of LabVIEW's Data Acquisition VI, allowing you to use various devices without complicated settings.

See <http://www.contec.com/vidaq/> for details and download of VI-DAQ.

Cable & Connector

■ Cable & Connector (Option)

Flat Cable with a 37-Pin D-type Connectors on 2Ends

: PCB37P-1.5 (1.5m)

: PCB37P-3 (3m)

: PCB37P-5 (5m)

Shielded cable with two 37-pin D-Type connectors

: PCB37PS-0.5P (0.5m)

: PCB37PS-1.5P (1.5m)

: PCB37PS-3P (3m)

: PCB37PS-0.5P (0.5m)

Flat Cable with a 37-pin D-type Connector

: PCA37P-1.5 (1.5m)

: PCA37P-3 (3m)

: PCA37P-5 (5m)

Shielded Cable with Two 37-pin D-Type Connectors

: PCA37PS-0.5P (0.5m)

: PCA37PS-1.5P (1.5m)

: PCA37PS-3P (3m)

: PCA37PS-5P (5m)

D-SUB37P Male Connector Set (5 Pieces) : CN5-D37M

Accessories

■ Accessories (Option)

Screw Terminal : EPD-37A *1

Screw Terminal : EPD-37 *1

Termination Panel (M3) : DTP-3(PC)

Termination Panel : DTP-4(PC)

Signal Monitor for Digital I/O : CM-32(PC)E *1

*1 A PCB37PS or PCB37PS optional cable is required separately.

* Check the CONTEC's Web site for more information on these options.

Product Configuration List

- Board(One of the following)

[PIO-16/16L(PCI)H, PI-32L(PCI)H, or PO-32L(PCI)H]

- First step guide ... 1

- CD-ROM *1 [API-PAC(W32)] ... 1

*1 The CD-ROM contains the driver software and User's Guide (this guide)

Using the On-board Connectors

◆ Connecting a Device to a Connector

To connect an external device to this board, plug the cable from the device into the interface connector shown below.

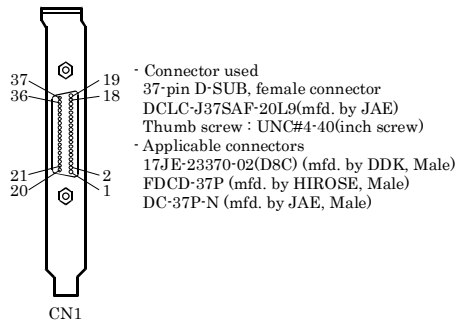
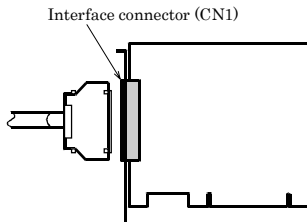

◆ Connector Pin Assignment

■ Pin Assignments of Interface Connector<PIO-16/16L(PCI)H>

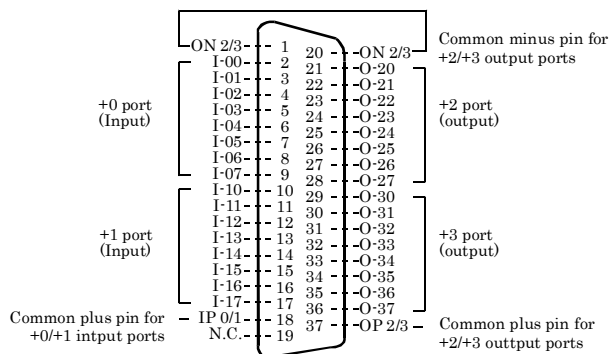

I-00 · I-17	16 input signal pins. Connect output signals from the external device to these pins.
O20 · O37	16 output signal pins. Connect these pins to the input signal pins of the external device.
IP 0/1	Connect the positive side of the external power supply. These pins are common to 16 input signal pins.
OP 2/3	Connect the positive side of the external power supply. These pins are common to 16 output signal pins.
ON 2/3	Connect the negative side of the external power supply. These pins are common to 16 output signal pins.
N.C.	This pin is left unconnected.

■ Pin Assignments of Interface Connector < PI-32L(PCI)H >

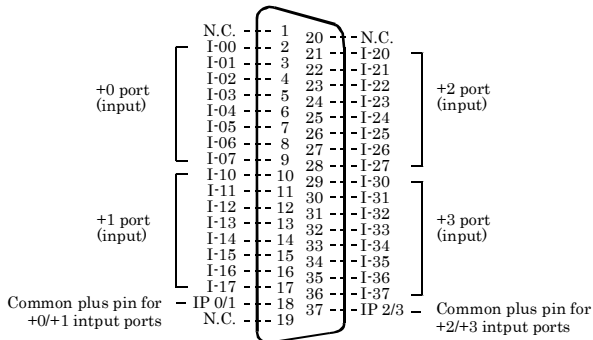

I-00 · I-37	32 input signal pins. Connect output signals from the external device to these pins.
IP 0/1 · IP 2/3	Connect the positive side of the external power supply. These pins are common to 16 input signal pins.
N.C.	This pin is left unconnected.

■ Pin Assignments of Interface Connector < PO-32L(PCI)H >

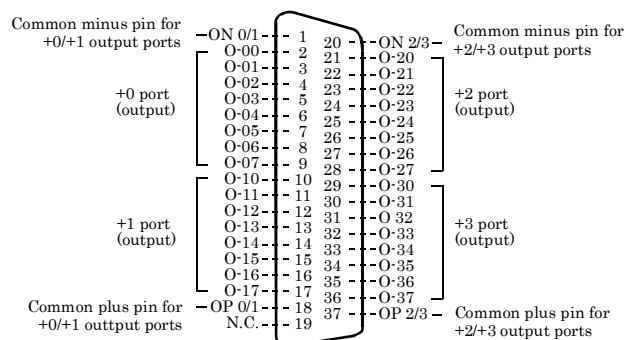

O-00 · O-37	32 output signal pins. Connect input signals from the external device to these pins.
OP 0/1 · OP 2/3	Connect the positive side of the external power supply. These pins are common to 16 output signal pins.
ON 0/1 · ON 2/3	Connect the negative side of the external power supply. These pins are common to 16 output signal pins.
N.C.	This pin is left unconnected.

Connecting Input Signals

Connect the input signals to a device which can be current-driven, such as a switch or transistor output device.

The connection requires an external power supply to feed currents. The board inputs the ON/OFF state of the current-driven device as a digital value.

◆ Input Circuit

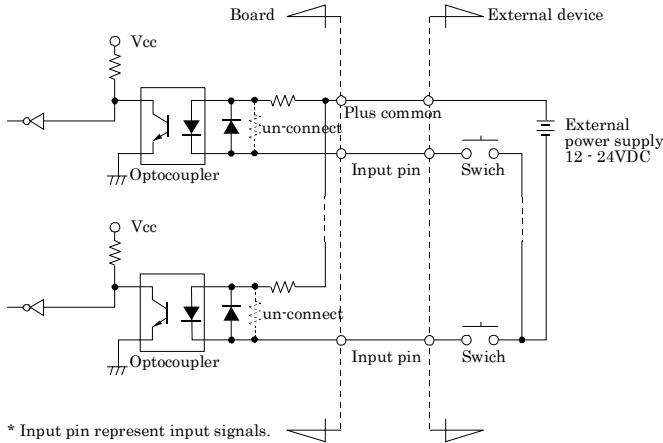

The input circuits of interface blocks of the PIO-16/16L(PCI)H and PO-32L(PCI)H are illustrated in Figure 3.5. The signal inputs are isolated by opto-couplers (ready to accept current sinking output signals). The board therefore requires an external power supply to drive the inputs. The power requirement for each input pin is about 5.1 mA at 24 VDC (about 2.6 mA at 12 VDC).

◆ Connecting a Switch

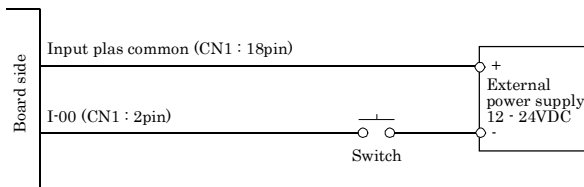

When the switch is ON, the corresponding bit contains 1.
When the switch is OFF, by contrast, the bit contains 0.

Connecting Output Signals

Connect the output signals to a current-driven controlled device such as a relay or LED.

The connection requires an external power supply to feed currents. The board controls turning on/off the current-driven controlled device using a digital value.

◆ Output Circuit

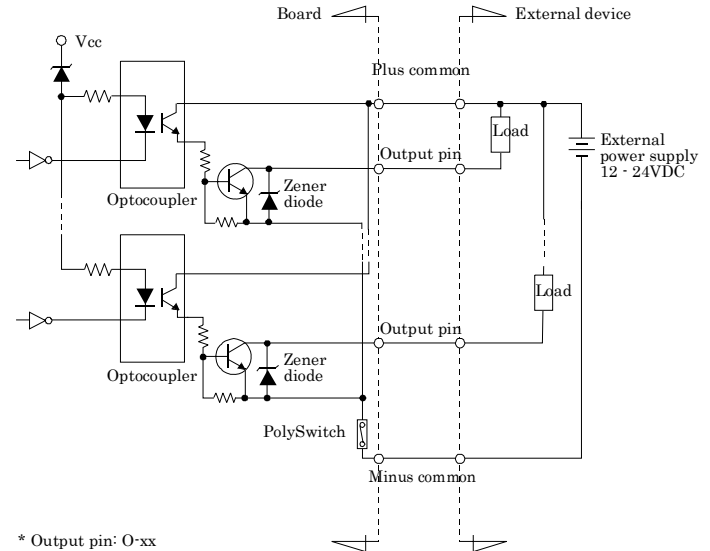

The output circuits of interface blocks of the PIO-16/16L(PCI)H and PO-32L(PCI)H are illustrated in Figure 3.7. The signal output section is an opto-coupler isolated, open-collector output (current sink type). Driving the output section requires an external power supply.

The rated output current per channel is 100 mA at maximum. The output section can also be connected to a TTL level input as it uses a low-saturated transistor for output. The residual voltage (low-level voltage) between the collector and emitter with the output on is 0.5 V or less at an output current within 50 mA or at most 1.0 V at an output current within 100 mA.

A zener diode is connected to the output transistor for protection from surge voltages. A PolySwitch-based overcurrent protector is provided for every eight output transistors. When the overcurrent protector works, the output section of the board is temporarily disabled. If this is the case, turn off the power to the PC and the external power supply and wait for a few minutes, then turn them on back.

▼ CAUTION

When the PC is turned on, all output are reset to OFF.

◆ Connection to the LED

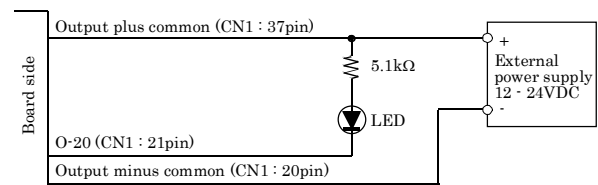

When "1" is output to a relevant bit, the corresponding LED comes on.
When "0" is output to the bit, in contrast, the LED goes out.

◆ Example of Connection to TTL Level Input

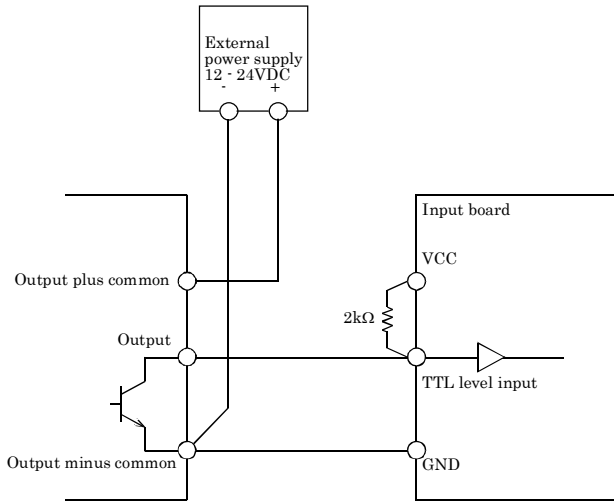

Connecting the Sink Type Output and Sink Output Support Input

The following example shows a connection between a sink type output (output board) and a sink output support input (input board). Refer to this connection example when you connect such boards to each other.

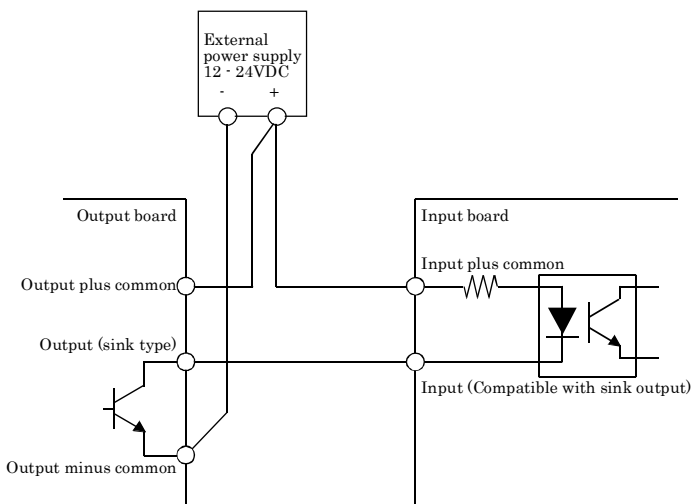

Block Diagram

■ PIO-16/16L(PCI)H

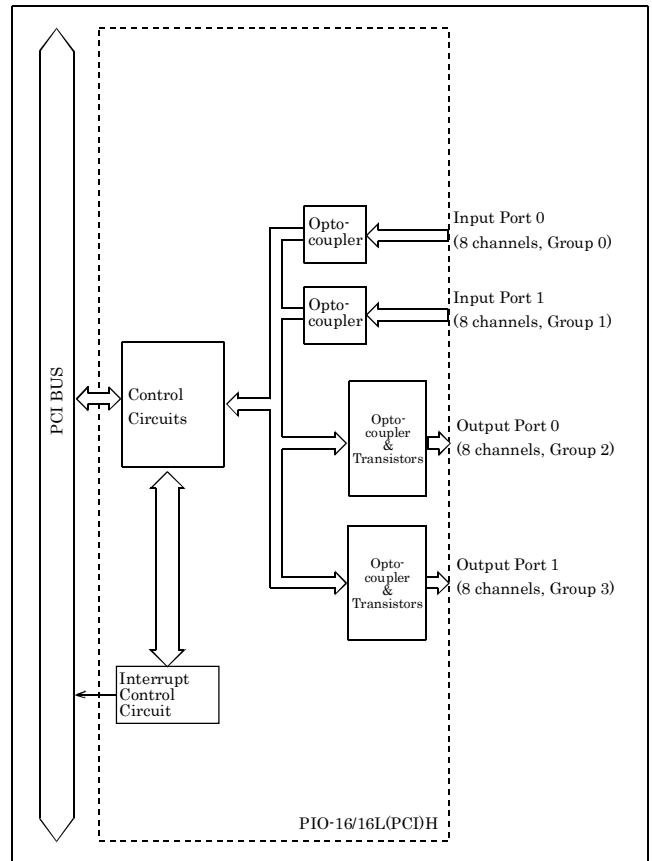

■ PI-32L(PCI)H

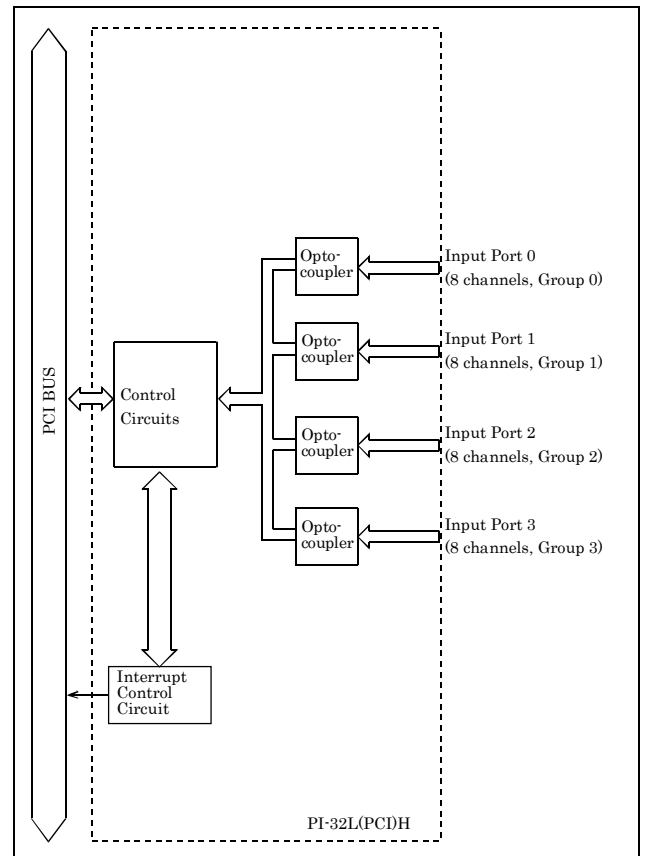

■ PO-32L(PCI)H

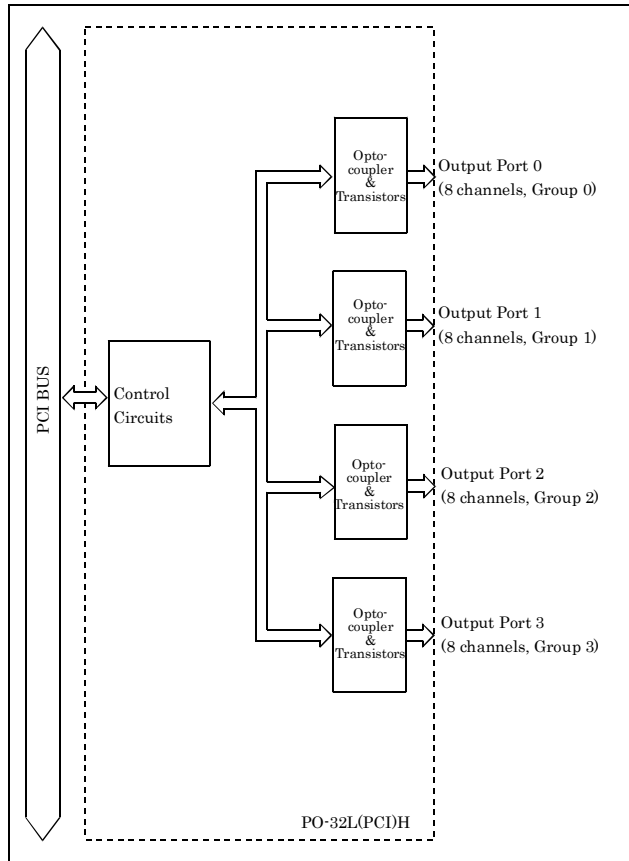

Differences between the PIO-16/16L(PCI)H and PIO-16/16L(PCI)

The PIO-16/16L(PCI)H is connector-pin compatible with the conventional PIO-16/16L(PCI) but has the following differences from it:

- (1) Different in the number of input signals available to interrupt requests

PIO-16/16L(PCI)H	: All of 16 channels
PIO-16/16L(PCI)	: 4 channels
- (2) Different in the expression to calculate the digital filter time (n: setting value)

PIO-16/16L(PCI)H	: $2n / (8 \times 106)$
PIO-16/16L(PCI)	: $2n / (16 \times 106)$
- (3) Protective elements provided for outputs

PIO-16/16L(PCI)H	: Surge protector: Zener diode
PIO-16/16L(PCI)	: Nothing
- (4) Different in interrupt level resource allocation

PIO-16/16L(PCI)H	: Automatically allocates on interrupt level.
PIO-16/16L(PCI)	: Uses a jumper switch to select whether to allocate interrupt levels.
- (5) Different in board dimensions

PIO-16/16L(PCI)H	: 121.69(L) x 105.68(H) mm
PIO-16/16L(PCI)	: 176.41(L) x 106.68(H) mm

Differences between the PI-32L(PCI)H and PI-32L(PCI)

The PI-32L(PCI)H is connector-pin compatible with the conventional PI-32L(PCI) but has the following differences from it:

- (1) Different in the number of input signals available to interrupt requests

PI-32L(PCI)H	: All of 32 channels
PI-32L(PCI)	: 4 channels
- (2) Different in the expression to calculate the digital filter time (n: setting value)

PI-32L(PCI)H	: $2n / (8 \times 106)$
PI-32L(PCI)	: $2n / (16 \times 106)$
- (3) Different in interrupt level resource allocation

PI-32L(PCI)H	: Automatically allocates on interrupt level.
PI-32L(PCI)	: Uses a jumper switch to select whether to allocate interrupt levels.
- (4) Different in board dimensions

PI-32L(PCI)H	: 121.69(L) x 105.68(H) mm
PI-32L(PCI)	: 176.41(L) x 106.68(H) mm

Differences between the PO-32L(PCI)H and PO-32L(PCI)

The PO-32L(PCI)H is connector-pin compatible with the conventional PO-32L(PCI) but has the following differences from it:

- (1) Protective elements provided for outputs

PO-32L(PCI)H	: Surge protector: Zener diode
PO-32L(PCI)	: Nothing
- (2) Different in board dimensions

PO-32L(PCI)H	: 121.69(L) x 105.68(H) mm
PO-32L(PCI)	: 176.41(L) x 106.68(H) mm

The specification, color, and design of a product may be changed without a preliminary announcement.